



HPE Networking Instant On Transceiver Guide

Transceiver Guide

Instant 



Hewlett Packard
Enterprise

Copyright Information

© Copyright 2024 Hewlett Packard Enterprise Development LP.

Open Source Code

This product includes code licensed under certain open source licenses which require source compliance. The corresponding source for these components is available upon request. This offer is valid to anyone in receipt of this information and shall expire three years following the date of the final distribution of this product version by Hewlett Packard Enterprise Company. To obtain such source code, please check if the code is available in the HPE Software Center at <https://myenterpriselicense.hpe.com/cwp-ui/software> but, if not, send a written request for specific software version and product for which you want the open source code. Along with the request, please send a check or money order in the amount of US \$10.00 to:

Hewlett Packard Enterprise Company Attn: General Counsel
WW Corporate Headquarters
1701 E Mossy Oaks Rd, Spring, TX 77389 United States of America



Table of Contents

Contents	3
Chapter 1 Overview	5
Types of transceiver modules and network cables	5
Data rate.....	5
Transmission distance	6
Central wavelength	6
Fiber	6
Connector	8
Optical parameters	8
Copper transceiver modules.....	8
Transmission distance.....	9
Connector.....	9
Operating Temperature.....	10
Identification of 4x4 part numbers.....	10
Unsupported transceivers.....	11
Supported vs Unsupported	13
Chapter 2 SFP+ Modules	15
SFP+ optical transceiver modules.....	15
Models, specifications, and compatibility	15
10G SFP+ copper transceiver modules	17
Models, specifications, and compatibility	17
SFP+ DAC cables	18
Models, specifications, and compatibility	18
Chapter 3 SFP Modules	20
Gigabit SFP optical transceiver modules.....	20
Models, specifications, and compatibility	20
Gigabit SFP copper transceiver modules	22
Models, specifications, and compatibility	22

Chapter 4 Support and Other Resources25
 Accessing HPE Networking Instant On Support.....25
 Other useful sites 25
 Accessing updates.....25
 OfficeConnect Support Portal25
 Warranty information26
 Regulatory information.....26
 Additional regulatory information 26
 Documentation feedback.....26

The transceivers listed in this document represent the currently available and End of Sale products at the time of this publication. Transceiver support varies from switch to switch within the HPE Networking Instant On product family, depending on hardware and/or software compatibility and limitations. To ensure support for your HPE Networking Instant On products, consult the switch model's product datasheet for a list of supported transceiver products.

Datasheets can be found at <https://instant-on.hpe.com/resources/>.

 NOTE: Product images in this guide may differ from actual product. The switch port numbers in this document are for illustration only and might be unavailable on your device.

Types of transceiver modules and network cables

Table 1: Types of transceiver modules and network cables

Transceiver module type	Description	Connector Type	Cable Type
Small Form-Factor Plus Pluggable (SFP+) module (transceiver)	10Gbps optical transceiver module	LC Duplex	OM1 - OM4 See Table 2 for more information
	10Gbps DAC (copper cable for interconnecting devices)	None	Twin-axial Direct Attached Cable
	10GBASE-T copper transceiver module	RJ-45	Requires CAT6A for maximum supported distances. Shielded STP cable recommended to eliminate EMI issues.
Small Form-Factor Pluggable (SFP) module (transceiver)	100-Megabit SFP optical transceiver module	LC Duplex	OM1 - OM4 See Table 2 for more information
	1Gbps SFP optical transceiver module		OM1 - OM4 See Table 2 for more information
	1G SFP copper transceiver module	RJ-45	Requires CAT5E for maximum supported distances

 NOTE: The table above only contains transceiver modules and network cables of link speeds relevant for HPE Networking Instant On portfolio

Data rate

Data rate is the number of bits transmitted per second. The unit of measure for data rate is Megabits per second (Mbps) or Gigabits per second (Gbps). Transceiver modules, optical, and Direct Attach over Copper (DAC) products provide the following levels of data rates:

- 10 Gbps (optical, DAC, and RJ45 10GBASE-T)
- 1000 Mbps (also known as Gigabit) (optical and RJ45 1000Base-T)
- 100 Mbps (also known as Fast Ethernet) (optical only)

Transmission distance

Through UTP or STP cables, signals can be transmitted over up to 100 m (328.08 ft.) only. This behavior occurs because signals attenuate during transmission through the UTP cables.

Attenuation refers to the dissipation of the power of a transmitted signal as it travels over a cable.

Attenuation occurs because signal transmission suffers certain resistance from the cable, which weakens the signals as they travel over the cable. When signals are transmitted over a long distance, signal strength decreases significantly, causing the signal-to-noise ratio to drop below the accepted level. This decrease makes it impossible to distinguish between signals and noise, which results in data loss.

Patch panel and punch down blocks also affect attenuation; that is, they can be a source of issues resulting in shorter distances or data loss.

10GBASE-T connections require Category 6a as a minimum for proper 10G speeds up to the 100m distance dictated by the IEEE 802.3ae standard for a fixed 10GBASE-T port. The S0G18A transceiver has a limit of 30m max distance due to limited power available to the transceiver (vs a fixed 10GBASE-T port). Anything less (Cat 6, 5e, 5) will compromise the distance that 10G over copper can achieve.

Shielded Twisted Pair (STP) Cat 6a cable is recommended when using the 10GBase-T transceiver (S0G18A).

Use of STP prevents EMI events from affecting data traffic carried on the wire - known as Crosstalk or Alien Crosstalk. Large EMI events from electronically noisy environments may be coupled onto unshielded cabling and cause temporary packet errors. Fixed 10G ports have designs to counteract these types of bit error conditions, that the 10GBASE-T transceiver cannot counteract consistently. Using STP Cat6a cables mitigate the errors significantly.

Central wavelength

Central wavelength (wl) represents the wave band used for optical signal transmission. The following central wavelengths are available for common optical transceiver modules representing three wavebands:

- 850 nm waveband: Used for short-reach transmission.
- 1310 nm and 1550 nm waveband: Used for middle-reach and long-haul transmission.

Fiber

Fibers are classified as multimode fibers and single-mode fibers.

Use patch cords with PC (Physical Contact Connector) or UPC (Ultra Physical Connector) types are supported. Patch cords with APC (Angled Physical Contact) connectors are not supported.

Multimode fibers

Multimode fibers (MMFs) have thicker fiber cores and can transport light in multiple modes. However, the intermodal dispersion is greater and worsens as the transmission distance increases.

Multimode fibers can be classified into multiple grades according to their diameters and modal bandwidth. The modal bandwidth of a multimode fiber is determined by the expression of the maximum modulation frequency pulse that can pass a fiber \times the fiber length. The modal bandwidth is a comprehensive index reflecting the optical characteristics of a multimode fiber.

International Telecommunication Union (ITU) defines multimode fiber types in its G series standards. The commonly used multimode fiber is defined in the ITU G.651 standard. The G.651-compliant fiber transmits light

at the wavelength range 800 nm to 900 nm or 1200 nm to 1350 nm.

Table 2: Multimode fiber grades

Fiber mode	Fiber grade	Fiber diameter (µm)	Modal bandwidth at 850 nm (MHz*km)
Multimode fiber	OM1	62.5/125	200
	OM2	50/125	500
	OM3	50/125	2000
	OM4	50/125	4700

Other factors that influence the transmission distance of multimode fibers include interface type, central wavelength, and fiber grade. The modal bandwidth values shown above are for the fiber grades listed. There are multimode fibers that have different modal bandwidth characteristics and do not necessarily match the OM1 - OM4 grades. See the individual transceiver specifications for distances supported when using MMF OM1-OM4. OM5 is a grade of multimode fiber that is primarily designed for short wave division multiplexing (SWDM) used by 40G speeds and higher. There usually is no distance advantage for 10G through 40G speeds that use single wavelengths over a fiber.

Single-mode fibers

Single-mode fibers (SMFs) have a small core size, typically 9 µm or 10 µm, and can transmit light in only one mode. Single-mode fibers suffer little intermodal dispersion and are suitable for long-haul communication. Single-mode fibers transmit light at the central wavelength of 1310 nm or 1550 nm.

Telecommunication Industries Alliance (TIA) / Electronic Industries Alliance (EIA) defines that single-mode fibers use yellow outer jackets with the mark "SM".

ITU defines single-mode fiber types in its G series standards. The most used single-mode fibers are defined in ITU G.652 and G.655 standards. The following table describes features of the G.652 and G.655-compliant fibers.

Table 3: Features of G.652- and G.655-compliant fibers

Single-mode fiber type	Wavelength (nm)	Features	Applications
G.652-compliant fiber (standard single-mode fiber)	1260 to 1360 1530 to 1565	Zero dispersion at 1310 nm	Connecting transceiver modules with a central wavelength of 1310 nm or 1550 nm.
G.655-compliant fiber (non-zero dispersion shifted fiber)	1530 to 1565	Near-zero dispersion around 1550 nm	For 1550 nm wavelength-division multiplexing (WDM) transmissions.

Fiber diameter

Fiber diameter is expressed as core diameter/cladding diameter, in µm. For example, 9/125 µm means that the fiber core diameter is 9 µm and the fiber cladding diameter is 125 µm.

For the HPE devices, the following fiber diameters are recommended:

- **G.651 standard multimode fiber:** 50/125 µm or 62.5/125 µm
- **G.652 standard single-mode fiber:** 9/125 µm
- **G.655 non-zero dispersion shifted single-mode fiber:** 9/125 µm

Connector



CAUTION: Cover the connector with a dust cap when it is not connected to any optical fibers

Connectors connect transceiver modules to the corresponding transmission media. The transceiver modules available for HPE Aruba Networking products use the following types of connectors:

Lucent connector or local connector (LC)

Single LC connectors (also known as Simplex) are typically used for 1G & 10G BiDi (Bidirectional) optics. Dual LC connectors (Duplex) are typically used in normal optical types.

Fiber connectors used for insertion into optical transceivers are typically of the ferrule polish type PC (Physical Contact) or UPC (Ultra Physical Contact). These minimize the air gap when inserted into a transceiver or when fiber-to-fiber mating.

Another type of polished end is the Angled Physical Contact usually with an 8° polished angle. Although this reduces reflected signal loss, the difficulty in mating the two angled surfaces limits it to only the most demanding splicing conditions.

Use PC or UPC type of fiber cables for use with transceivers.

Figure 1 LC connector (Simplex = single fiber, Duplex = dual fiber)



Optical parameters

This guide provides average transmit and receive power ranges for transceiver modules.

Transmit Power

Transmit power is the power at which the transmitter of an optical transceiver module transmits optical signals, in dBm.

Receive Sensitivity

Receive power is the power at which the receiver of an optical transceiver module receives optical signals, in dBm.

Using Attenuators (for short test cables)

Transceivers are designed to transmit light pulses at power levels that account for loss in the fiber optic cabling and meet the receiver input thresholds of the link partner optical transceiver.

If you are using a fiber cable with less light loss than expected (for example, in a test environment and you do not have a 10km spool of SMF available), use attenuators to reduce the transmit level to be within the receive sensitivity of the other transceiver -- you will need to condition both fibers (sends in both directions). If not done, you risk overdriving the Receive end and permanently damaging the transceiver.

Copper transceiver modules

Copper transceiver modules transmit signals over Category -5, -5e, -6, and -6a unshielded twisted pair (UTP) or shielded twisted pair (STP). UTP transmission covers shorter distances than fiber transmission and can be used in small-sized networks only. 10G over twisted pair requires the use of Category 6 and 6a to achieve the full 100m

as per the 10GBASE-T standard for fixed 10GBASE-T ports.

1G and 10G copper transceivers are supported in 1Gbps SFP and 10Gbps SFP+ ports as listed in the compatibility tables as well as the switch datasheets.

Transmission distance

Through UTP or STP cables, signals can be transmitted over a distance of upto 100 m (328.08 ft.) only. This behavior occurs because signals attenuate during transmission through the UTP cables.

Attenuation refers to the dissipation of the power of a transmitted signal as it travels over a cable.

Attenuation occurs because signal transmission suffers certain resistance from the cable, which weakens the signals as they travel over the cable. When signals are transmitted over a long distance, signal strength decreases significantly, causing the signal-to-noise ratio to drop below the accepted level. This decrease makes it impossible to distinguish between signals and noise, which results in data loss.

Patch panel and punch down blocks also affect attenuation; that is, they can be a source of issues resulting in shorter distances or data loss.

10GBASE-T connections require Category 6a as a minimum for proper 10G speeds up to the 100m distance dictated by the IEEE 802.3ae standard for a fixed 10GBASE-T port. The S0G18A transceiver has a limit of 30m max distance due to limited power available to the transceiver (vs a fixed 10GBASE-T port). Anything less (Cat 6, 5e, 5) will compromise the distance that 10G over copper can achieve.

Shielded Twisted Pair (STP) Cat 6a cable is recommended when using the 10GBase-T transceiver.

Use of STP prevents EMI events from affecting data traffic carried on the wire - known as Crosstalk or Alien Crosstalk. Large EMI events from electronically noisy environments may be coupled onto unshielded cabling and cause temporary packet errors. Fixed 10G ports have designs to counteract these types of bit error conditions, that the 10GBASE-T transceiver cannot counteract consistently. Using STP Cat6a cables mitigate the errors significantly.

Connector

Registered Jack-45 (RJ-45) twisted-pair connectors are used as connectors for copper transceiver modules.

Figure 2 *Rj-45 connector*

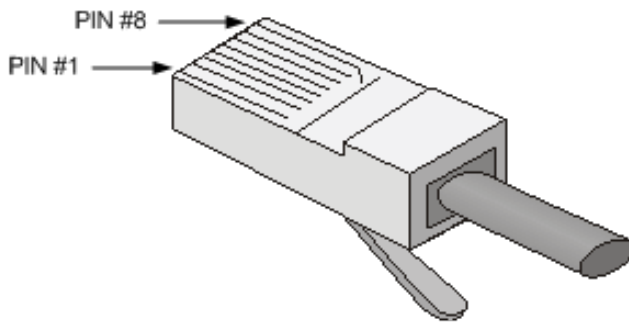

Table 4: RJ-45 GE connector pin assignment for Gigabit connections

Pin	Signal	Function
1	MX_0+	Data transmit/receive

2	MX_0-	Data transmit/receive
3	MX_1+	Data transmit/receive
4	MX_2+	Data transmit/receive
5	MX_2-	Data transmit/receive
6	MX_1-	Data transmit/receive
7	MX_3+	Data transmit/receive
8	MX_3-	Data transmit/receive

Operating Temperature

HPE Networking Instant On Transceivers supports an operating temperature range of **0°C to 70°C** (Zero degree Celsius to Seventy degree Celsius.)

Operating temperature range:

- Commercial temperature range (COM): 0 to 70°C (32 to 158°F)
- Extended temperature range (EXT): -5 to 85°C (23 to 185°F)
- Industrial temperature range (IND): -40 to 85°C (-40 to 185°F)

HPE Networking Instant On Transceivers should be stored in the temperature range of **-40°C to 85°C** (Negative Forty degree Celsius to Eighty-five degree Celsius.)

Storage temperature range:

- Storage temperature range: -40 to 85°C (-40 to 185°F)



NOTE: Switch operational and storage temperatures would vary from the ranges mentioned. The operating temperature ranges here refer to the transceiver's operating temperature, i.e. the transceiver's temperature due to the switch heating up. E.g. a switch operating at 45°C could heat up the transceiver to its max operating temperature of 70°C.

Identification of 4x4 part numbers

A SKU# (Stock Keeping Unit, also called a Product Number or Part Number) may be fulfilled by one or more vendor parts providing similar functionality. A 4x4 (or "4 by 4") part number is of the form and is printed on the transceiver, or DAC label. For example, R9D19A (10G DAC) may have 8121-1789 or 8121-1792 as the associated 4x4 part number.

4x4 part numbers are referenced in the:

- Specification tables, to identify parts that support DOM (Digital Optical Monitoring) capabilities. (Some older vendor parts do not support DOM.)
- Compatibility tables, where necessary, to identify supported combinations of switch or module with the identified transceiver, along with the minimum software version required.

HPE Aruba Networking introduced J4859D in December 2017, and J9151E in 2019, revised versions of 1000BASE-LR, and 10GBASE-LR products, eliminating previous versions and associated with alternative vendors, so that Instant On customers can be assured that certified vendor parts are fully supported on HPE Networking Instant On Switch products. Earlier Revision of each Module A, B, C, and D (for 10G BASE-LR) product may have previous generation versions never tested on HPE Networking Instant On and therefore are not supported.

To cross-reference the Transceiver/DAC product against the switch product to identify the minimum software required for transceiver support, always refer to the most recently published Datasheet for the switch product to see the current list of supported transceivers. Refer to the compatibility tables within this document.

Unsupported transceivers

The term "transceiver" applies collectively to optical transceivers and DAC cables. HPE Networking Instant On does not limit operations to officially supported transceivers listed in this document and product datasheets. Proper operations, however, are not guaranteed while using "third-party / unsupported transceivers". The flexibility of not blocking traffic when "unsupported transceivers" are inserted in Instant On switches can assist in the initial installation or validation of switching products while customers obtain fully supported products.

The term "third-party transceiver" applies to transceiver parts not specifically identified on datasheets or in this guide. Transceivers sold by HPE Aruba Networking for use on other switches/controllers not listed within this guide or sold by HPE for use on HPE Servers or Storage devices are also considered "third-party". "Third-party transceivers" are not supported by HPE Networking Instant On support team on Instant On switches and therefore interoperability, quality, stability, and reliability cannot be guaranteed by HPE Aruba Networking. This guide indicates the specific and recommended transceiver products and minimum software version required for full support. Older generation transceivers may not be fully supported on newer generations of switch models. For questions, contact your HPE Networking Instant On Account Team.

Using "third-party" products present these caveats:

- An unsupported transceiver is used by the customer at their own risk.
- HPE Networking Instant On assumes no liability to ensure the proper operation of a product not designed/designated as supported, even from future revisions of Instant On product firmware. No guarantees are implied that a "third-party" transceiver will continue to work from release to release.
- "Third-party" transceiver products are not under the control of HPE Networking Instant On, so HPE Networking Instant On has no knowledge of changes in design and cannot vouch for the quality of the third-party part, nor any assurance that the parts are the same from time to time. HPE Networking Instant On devices are not tested with unsupported transceivers.

Here are some **Frequently Asked Questions** regarding HPE Networking Instant On Transceivers:

1. Will using third-party transceiver parts void my switch warranty?

Perhaps. Using third-party transceivers *may* affect your switch warranty. If it is validated that the failure has been triggered by the third-party parts, the switch product will not be replaced under warranty. Third-party parts will not be replaced by HPE Networking Instant On warranty support – contact the original reseller of your third-party parts for replacement.

2. Will my HPE Networking Instant On transceiver and/or cable warranty be voided if deployed in a third-party device?

Not necessary. However, to validate the replacement, HPE Networking Instant On will ask to test the transceiver or the cable in a supported environment (i.e., in an HPE Networking Instant On switch) to validate that the transceiver is defective and to rule out a defect from the third-party device.

3. Will I receive support for my HPE Networking Instant On device if an unsupported transceiver or cable is inserted?

No. HPE Networking Instant On switches warranty is extended to customers for supported operations. If an Instant On switch is operated with an unsupported transceiver and such transceiver does damage the switch (from overheating as example: High power budget transceivers exceeding the Instant On switch heat dissipation specifications), HPE Networking Instant On keeps the right to void the warranty of the Instant On switch. Please refer to the [switch datasheets](#) for the list of supported transceiver and cables.

4. Will I receive support for my HPE Networking Instant On transceivers and/or cable if inserted in a third-party (including non-HPE Networking Instant On) device?

No. HPE Networking Instant On transceivers listed in this guide may not be supported with a third-party or non-Instant On device. It would be up to the third-party company (including HPE) that sold the device to certify support of the HPE Networking Instant On transceivers. In such cases, the Technical Assistance Center (TAC) cannot help customers with this issue as HPE Networking Instant On has no way to replicate the customer problem if it occurs on a third-party device.

5. Will the Technical Assistance Center (TAC) take my support call?

Depends on the case. When it is determined that an issue may involve questionable connectivity using third-party transceivers (including optics/DACs), TAC may ask that you replace the third-party transceiver with a transceiver supported for use with HPE Networking Instant On switches before continuing troubleshooting activities. The support call may be paused until this is done, eliminating the suspicion of the third-party transceiver as a possible issue.

Please refer to the [switch datasheets](#) for the list of supported transceiver and cables for use in each HPE Networking Instant On switch model.

For further information or questions, consult your HPE Networking Instant On Sales team member.

6. What is the warranty period for HPE Networking Instant On transceivers?

HPE Networking Instant On transceivers come with a 3-year warranty from the date of purchase.

7. If purchased from an authorized HPE Networking Instant On Partner and used in an HPE Networking Instant On switch, will I be eligible for warranty?

Yes.

8. How does HPE Networking Instant On evaluate the eligibility of an HPE Networking Instant On cable or transceiver for warranty coverage?

When a technical support case is submitted to our HPE Networking Instant On Welcome Center, the agent will request some references like proof of purchase, part number and serial number (when it applies), to validate the product in HPE's database and to determine the next steps, if part of the issue resolution is a hardware replacement.

9. Is the warranty transferable?

No. HPE Networking Instant On warranty is available only to the original end user who purchased HPE Networking Instant On through an authorized HPE Networking Instant On distribution channel. HPE Networking Instant On may request proof of purchase of your HPE Networking Instant On transceiver from an authorized vendor in order to establish warranty eligibility.

10. Can I purchase a Foundation Care Pack just for Instant On Transceivers separately, and use it with third-party devices?

No. Foundation Care packs are offered only for HPE Networking Instant On switches and access points.

11. How can I extend the warranty of an HPE Networking Instant On transceiver?

HPE Networking Instant On does not offer warranty extension for the transceiver itself beyond the default warranty period. However, upon purchase of Foundation Care for HPE Networking Instant On ("Foundation Care") support services package for an HPE Networking Instant On switch, the HPE Networking Instant On transceivers inserted in the switch benefit from the same warranty extension as the switch.

12. If my switch warranty is limited lifetime vs my transceiver warranty is 3 years, is my transceiver under no warranty after the first 3 years, even though my switch still remains under warranty?

Yes. The transceiver warranty will only be extended if a Foundation Care pack is bought for the switch.

13. How are HPE Networking Instant On transceivers supported by HPE Networking Instant On?

Support for replacing failed units is covered by the warranty and RMA questions above.

Support for networking issues and troubleshooting is only offered through Foundation Care services packages sold for HPE Networking Instant On switches, covering for the HPE Networking Instant On transceiver used with them.

When a customer calls HPE Networking Instant On with a switching issue, the problem is troubleshooted with officially supported HPE Networking Instant On transceivers and cables in the switch. The troubleshooting covers both the switch itself and its HPE Networking Instant On cables and transceivers.

Customers calling HPE Networking Instant On support for HPE Networking Instant On transceivers and cables inserted in devices other than Instant On switches (please refer to the [switch datasheets](#) for the list of supported transceiver and cables for use in each HPE Networking Instant On switch model), cannot be assisted since HPE Networking Instant On does not have third-party devices nor the software running on them. The behavior of HPE Networking Instant On cables and transceivers in non-tested systems is unknown by HPE Networking Instant On. The customer is taking a chance as it may work or may not work.

14. How do I check if I have a counterfeit transceiver?

You can review the validity of the Security ID by visiting: <https://www.hpe.com/us/en/validate.html> and downloading the HPE Parts Validation App from the Apple App or Google Play stores. An invalid Security ID indicates potential counterfeit. Please follow the steps for visual inspection, before contacting hardware.counterfeitvalidation@hpe.com for authentication support.



NOTE: There is no guarantee that an unsupported transceiver WILL be enabled; however, it can be attempted, without HPE Networking Instant On guarantee of proper operation.

Supported vs Unsupported

Simply because a part is enabled for use, does not mean that it is "supported".

- Supported products are listed and covered by the terms found on the [Product Warranty and Support](#) page.
- Supported product warranty can be extended (beyond their original warranty) with a Support Contract on the covered HPE Networking Instant On switch (the inserted transceivers are covered by the switch contract).
- For issues involving questions related to interoperability, quality, or reliability using an unsupported transceiver (optics/DACs), the Technical Assistance Center (TAC) may ask that you replace the third-party transceiver with a product supported for use with HPE Networking Instant On switches before continuing troubleshooting activities.

- Even if a product displays a part number as a "supported" product part number, however, if the TAC discovers that the part is not a genuine HPE Aruba Networking or HPE Networking Instant On part (that is, a counterfeit or a compatible product), then in that case, support may not be available. Damage to the switch or port would not be covered under the warranty.
- The local or cloud management may display unreliable module information, such as Digital Optical Monitoring DOM data. The accuracy of the electronic information in third-party products is unknown to and not verified by HPE Networking Instant On. The information is reported on a best-effort basis. HPE Networking Instant On firmware may or may not use any information provided by a third-party/unsupported transceiver.

This guide details products that are supported by a switch model or module. In some cases, a particular switch model or module may not have the proper hardware or software support to allow a transceiver technology to work at all. This guide denotes that limitation with a comment about "or any type of {type of} technology". For example: 10G LRM technology is not supported in any Instant On switch model.

Transceiver products (including DACs) have identification information within the product - this information is read when the transceiver is inserted into the switch. HPE Networking Instant On switches use this information to validate whether the part is a "supported" product. If not, it is officially "unsupported" and usually shown as such.

Some considerations for third-party products:

- Do they follow the guidelines agreed upon by Multi-Source Agreement (MSA) vendors?
- Many low-cost products do not properly code the MSA required fields for type, distance, media type among other fields, or they may incorrectly identify the part, causing the switch to enable them with settings not appropriate for the type of transceiver inserted.
- Do the Third-Party products meet all IEEE and design requirements that are satisfied by HPE Networking Instant On transceivers?
- Third-party products may substitute an updated or a revised version of the transceivers over the lifecycle of the product without proper notification or release notes. Therefore, Third-Party product's compatibility may vary from sample to sample.

Hewlett Packard Enterprise Company consists of different divisions and product families. The HPE Networking Instant On division is a dedicated Instant On brand and product line for Small-to-medium Business. Transceiver products that are designed to work with specific HPE division products or HPE Aruba Networking Enterprise switches may not work properly on HPE Networking Instant On switches. For this reason, until the HPE Networking Instant On team has certified other HPE Aruba Networking Enterprise products as compatible with HPE Networking Instant On switches, those products may be identified as third-party, and their complete operation and full support is not guaranteed.

Similarly, an HPE Networking Instant On transceiver listed in this guide may not be supported on a non-HPE Networking Instant On or OfficeConnect switch. It would be up to the 3rd party company or HPE division that developed the device to certify support of the HPE Networking Instant On transceiver and the Technical Assistance Center (TAC) cannot help customers with this issue.

SFP+ optical transceiver modules

In 2019, HPE Aruba Networking introduced Revision E version of J9151E SKU 10G transceivers. Revision E product is structured to be specific alternate vendors as sources for the SKU#. Earlier Revision A, B, Cor D product may have alternate vendors that we are not tested on Instant On switches and are not supported.

Always refer to the datasheet or this guide for the switch product to see the current list of supported transceivers.

Figure 3 SFP+ optical transceiver modules

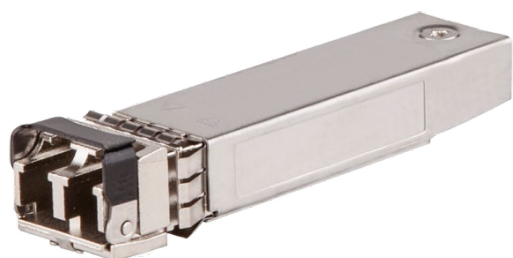

NOTE: Although a 10Gbps SFP+ transceiver module has the same physical dimensions of a 1Gbps SFP transceiver, a 10Gbps transceiver will NOT operate in a 1Gbps SFP port.

NOTE: Product images in this guide may differ from actual product

10Gbps SFP+ ports also support 1Gbps SFP transceivers. Please refer to the datasheet for the switch product and verify which SFP transceivers are supported in your product's SFP+ ports.

Models, specifications, and compatibility

SFP+ optical transceiver modules provide a transmission rate of 10.31 Gbps and use LC connectors.

Table 5: Specifications for SFP+ Optical Transceiver Modules

Product Name (SKU)	DOM - Digital Optical Monitoring (4x4 part #)	Central wl (nm)	Fiber mode	Fiber diameter (µm)	Bandwidth (MHz*km)	Transmission distance
HPE Aruba Networking 10G SFP+ LC SR 300m OM3 MMF Transceiver (J9150D)	Yes J9150D: (1990-4391, 1990-4635, 1990-4634, 1990-4175)	850	MMF	50/125	4700 (OM4) 2000 (OM3) 500 (OM2) 400	400m (1312.34 ft) 300m (984.25 ft) 82m (269.03 ft) 66m (216.54 ft)
HPE Networking Instant On 10G SFP+ LC SR 300m OM3 MMF Transceiver (R9D18A)	R9D18A: (1990-4839, 1990-4833)			62.5/125	200 (OM1) 160	33m (108.27 ft) 26m (85.30)

						ft)
HPE Aruba Networking 10G SFP+ LC LR 10km SMF Transceiver (J9151E)	Yes J9151E: (1990-4657, 1990-4694)	1310	SMF	9/125	N/A	10km (6.21 miles)
HPE Networking Instant On 10G SFP+ LC LR 10km SMF Transceiver (S0G21A)	S0G21A: (1990-4915, 1990-4932)					

Table 6: Specifications for SFP+ Optical Parameters

Product Name (SKU)	Optical parameters (dBm)	
	Transmit power	Receive Power
HPE Aruba Networking 10G SFP+ LC SR 300m OM3 MMF Transceiver (J9150D) HPE Networking Instant On 10G SFP+ LC SR 300m OM3 MMF Transceiver (R9D18A)	-7.3 to -1	-9.9 to +0.5
HPE Aruba Networking 10G SFP+ LC LR 10km SMF Transceiver (J9151E) HPE Networking Instant On 10G SFP+ LC LR 10km SMF Transceiver (S0G21A)	-8.2 to +0.5	-14.4 to +0.5

Table 7: Software Compatibility for the SFP+ Optical Transceiver Modules

Product Series	SKU	Minimum software required			Comments
		10G-SR (J9150D), 10G-LR (J9151E)	10G-SR (R9D18A)	10G-LR (S0G21A)	
HPE OfficeConnect 1420	JH018A	All		No support	For use in SFP+ capable ports
HPE Networking Instant On 1930 (A)	JL682A, JL683A, JL684A, JL685A, JL686A	V1.0.1	V2.5.0	V2.9.1	For use in SFP+ capable ports
HPE Networking Instant On 1930 (B)	JL683B, JL684B, JL686B	V2.5.0	V2.5.0	V2.9.1	For use in SFP+ capable ports

HPE OfficeConnect 1950	JH295A, JG960A, JG961A, JG962A, JG963A	1950_7.10. R3507 and 1950_12XGT_7.10. R5106P06		No support	For use in SFP+ capable ports
HPE Networking Instant On 1960	JL805A, JL806A, JL807A, JL808A, JL809A	V2.4.0	V2.5.0	V2.9.1	For use in SFP+ capable ports
HPE Networking Instant On 1960	S0F35A	V2.8.1	V2.8.1	V2.9.1	For use in SFP+ capable ports

10G SFP+ copper transceiver modules

Figure 4 Gigabit SFP copper transceiver module

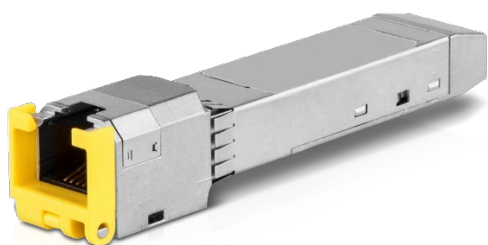

Models, specifications, and compatibility



NOTE: Although a 10GBASE-T SFP+ transceiver module has the same physical dimensions of a 1GBASE-T SFP transceiver, a 10GBASE-T transceiver is not supported in 1Gbps SFP ports.

NOTE: Product images in this guide may differ from actual product

Table 8: Specifications for SFP Copper Transceiver Modules

Product Name (SKU)	4x4 part #	Transmission distance	Data rate	Cable type	Connector type
HPE Aruba Networking 10GBASE-T SFP+ RJ45 30m Cat6A Transceiver (JL563C)	1990-4855	30m (98.43 ft)	10G	STP Cat6A**	RJ-45
HPE Networking Instant On 10GBASE-T SFP+ RJ45 30m Cat6A Transceiver (S0G18A)	1990-4913				

**See [Transmission distance](#)

Table 9: Software Compatibility for SFP Copper Transceiver Modules

Product Series	SKU	Minimum software required		Comments
		S0G18A	JL563C	
HPE Networking Instant On 1930	JL682A, JL683A, JL684A, JL685A, JL686A, JL683B, JL684B, JL686B	V2.9.1	V3.0.0	For use in SFP and SFP+ capable ports. 1000Mbps is not supported.
HPE Networking Instant On 1960	JL805A, JL806A, JL807A, JL808A, JL809A, S0F35A	V2.9.1	V3.0.0	For use in SFP and SFP+ capable ports. 1000Mbps is not supported.

SFP+ DAC cables

Figure 5 10G SFP+ DAC Cable



NOTE: Direct Attach over Copper (DAC) cables have a minimum bend radius of typically 4x the diameter of the cable (approximately a 1" bend radius). Handle DAC cables carefully to ensure that you do not crimp or bend the cable beyond a 1" radius; otherwise, you risk damaging the cable.

NOTE: Product images in this guide may differ from actual product

10Gbps DAC cables are not applicable for ports that only support 1Gbps SFP transceivers.

Models, specifications, and compatibility

Table 10: Specifications for SFP+ DACs

Product name (SKU)	4x4 part #	Cable length	Data rate
HPE Aruba Networking 10G SFP+ to SFP+ 1m Direct Attach Copper Cable (J9281D)	8121-1152, 8121-1300	1 m (3.28 ft)	
HPE Networking Instant On 10G SFP+ to	8121-1789,		

SFP+ 1m Direct Attach Copper Cable (R9D19A)	8121-1792	3 m (9.84 ft)	10 Gbps
HPE Aruba Networking 10G SFP+ to SFP+ 3m Direct Attach Copper Cable (J9283D)	8121-1152, 8121-1298		
HPE Networking Instant On 10G SFP+ to SFP+ 3m Direct Attach Copper Cable (R9D20A)	8121-1790, 8121-1791		

Table 11: Software Compatibility for the SFP+ DAC cables

Product Series	SKU	Minimum software required		Comments
		J9281D, J9283D	R9D19A, R9D20A	
HPE OfficeConnect 1420	JH018A	All		For use in SFP+ capable ports
HPE Networking Instant On 1930 (A)	JL682A, JL683A, JL684A, JL685A, JL686A	V1.0.1	V2.5.0	For use in SFP+ capable ports
HPE Networking Instant On 1930 (B)	JL683B, JL684B, JL686B	V2.5.0	V2.5.0	For use in SFP+ capable ports
HPE OfficeConnect 1950	JH295A, JG960A, JG961A, JG962A, JG963A	1950_7.10. R3507 and 1950_12XGT_7.10. R5106P06		For use in SFP+ capable ports
HPE Networking Instant On 1960	JL805A, JL806A, JL807A, JL808A, JL809A	V2.4.0	V2.5.0	For use in SFP+ capable ports
HPE Networking Instant On 1960	S0F35A	V2.8.1	V2.8.1	For use in SFP+ capable ports

Gigabit SFP optical transceiver modules

HPE Aruba Networking introduced J4859D in December 2017, revised version of 1G LX product, eliminating previous versions and associated with alternative vendors, so that Instant On customers can be assured that only certified vendor parts are supported on HPE Networking Instant On Switch products. Earlier Revision A, B and C product may have alternative vendors never tested on HPE Networking Instant On and therefore are not supported.

Always refer to the datasheet or this guide for the switch product to see the current list of supported transceivers.

Figure 6 Gigabit SFP optical transceiver module



NOTE: Although a 10Gbps SFP+ transceiver module has the same physical dimensions of a 1Gbps SFP transceiver, a 10Gbps transceiver is not supported in 1Gbps SFP ports.

NOTE: Product images in this guide may differ from actual product

10Gbps SFP+ ports also support 1Gbps SFP transceivers. Please refer to the datasheet for the switch product and verify which SFP transceivers are supported in your product's SFP+ ports.

Models, specifications, and compatibility

Gigabit SFP optical transceiver modules use LC connectors.

Table 12: Specifications for Gigabit SFP Optical Transceiver Modules

Product Name (SKU)	DOM - Digital Optical Monitoring (4x4 part #)	Central wl (nm)	Fiber mode	Fiber diameter (µm)	Bandwidth (MHz*km)	Transmission distance
HPE Aruba Networking 1G SFP LC SX 500m OM2 MMF Transceiver	Yes J4858D: (1990-4415, 1990-4395,	850	MMF	50/125	500 (OM2) 400	550m (1804.46 ft) 500 m (1640.42 ft)

(J4858D) HPE Networking Instant On 1G SFP LC SX 500m OM2 MMF Transceiver (R9D16A)	1990-4750, 1990-4793) R9D16A: (1990-4834, 1990-4835, 1990-4836)			62.5/1 25	200 (OM1) 160	275m (902.23 ft) 220m (721.78 ft)
HPE Aruba Networking 1G SFP LC LX 10km SMF Transceiver (J4859D)	Yes J4859D: (1990-4802, 1990-4762)	1310	SMF	9/125	N/A	10km (6.21 miles)
			MMF	50/12 5	500 (OM2) or 400	550m (1804.46 ft)
HPE Networking Instant On 1G SFP LC LX 10km SMF Transceiver (S0G20A)	S0G20A: (1990-4914), (1990-4969)		MMF	62.5/1 25	500 (OM2) 200 (OM1)	550m (1804.46 ft)

Table 13: Specifications for Gigabit SFP Optical Parameters

Product Name (SKU)	Optical parameters (dBm)	
	Transmit power	Receive Power
HPE Aruba Networking 1G SFP LC LX 10km SMF Transceiver (J4858D) HPE Networking Instant On 1G SFP LC SX 500m OM2 MMF Transceiver (R9D16A)	-9.5 to 0	-17 to -3
HPE Aruba Networking 1G SFP LC LX 10km SMF Transceiver (J4859D) HPE Networking Instant On 1G SFP LC LX 10km SMF Transceiver (S0G20A)	-9.5 to -3	-20 to -3

Table 14: Software Compatibility for the Gigabit SFP Optical Transceiver Modules

Product Series	SKU	Minimum software required			Comments
		1G-SX (J4858D) , 1G-LX (J4859D)	1G-SX (R9D16A)	1G-LX (S0G20A)	
HPE OfficeConnect 1420	JH017A, JH018A	All		No support	For use in SFP and SFP+ capable ports
HPE Networking	R8R50A	All		V2.9.1	For use in SFP

Instant On 1430					and SFP+ capable ports
HPE OfficeConnect 1820	J9980A, J9981A, J9983A, J9984A	All		No support	For use in SFP and SFP+ capable ports
HPE Networking Instant On 1830	JL812A, JL813A, JL814A, JL815A	V2.5.0	V2.5.0	V2.9.1	V2.9.1 For use in SFP and SFP+ capable ports
HPE OfficeConnect 1920S	JL381A, JL382A, JL384A, JL385A, JL386A	All		No support	For use in SFP and SFP+ capable ports
HPE Networking Instant On 1930 (A)	JL680A, JL681A, JL682A, JL683A, JL684A, JL685A, JL686A	V1.0.1	V2.5.0	V2.9.1	For use in SFP and SFP+ capable ports
HPE Networking Instant On 1930 (B)	JL683B, JL684B, JL686B	V2.5.0	V2.5.0	V2.9.1	For use in SFP and SFP+ capable ports
HPE OfficeConnect 1950	JH295A, JG960A, JG961A, JG962A, JG963A	1950_7.10. R3507 and 1950_12XGT_7.10. R5106P06		No support	For use in SFP and SFP+ capable ports
HPE Networking Instant On 1960	JL805A, JL806A, JL807A, JL808A, JL809A	V2.4.0	V2.5.0	V2.9.1	For use in SFP and SFP+ capable ports
HPE Networking Instant On 1960	S0F35A	V2.8.1	V2.8.1	V2.9.1	For use in SFP and SFP+ capable ports

Gigabit SFP copper transceiver modules

Figure 7 Gigabit SFP copper transceiver module

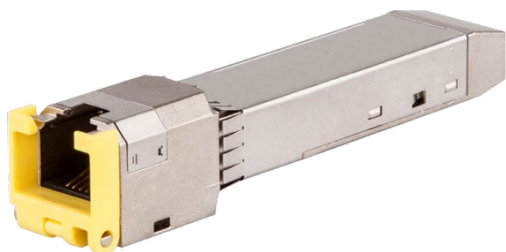

Models, specifications, and compatibility

Gigabit SFP optical transceiver modules use LC connectors.



NOTE: Although a 10GBASE-T SFP+ transceiver module has the same physical dimensions of a 1GBASE-T SFP transceiver, a 10GBASE-T transceiver is not supported in 1Gbps SFP ports.

NOTE: Product images in this guide may differ from actual product

Table 15: Specifications for SFP Copper Transceiver Modules

Product Name (SKU)	4x4 part #	Transmissi on distance	Data rate	Cable type	Connector type
HPE Aruba Networking 1G SFP RJ45 T 100m Cat5e Transceiver (J8177D)	1990-3816, 1990-4606, 1990-4640	100 m (328.08 ft) Full distance requires Category 5e cable	1G 100Mbps (For certain products. See next table)	Cat5e UTP/STP	RJ-45
HPE Networking Instant On 1G SFP RJ45 100m Cat5e Transceiver (R9D17A, R9D17B)	1990-4837, 1990-4838				

Table 16: Software Compatibility for SFP Copper Transceiver Modules

Product Series	SKU	Minimum software required			Comments
		J8177D	R9D17A	R9D17B	
HPE OfficeConnect 1420	JH017A, JH018A	All		No support	For use in SFP and SFP+ capable ports. 100Mbps is supported on the JH017A on SFP ports. 100Mbps is unsupported on the JH018A SFP+ ports. 1000Mbps is supported on both JH017A and JH018A SFP/SFP+ ports.
HPE OfficeConnect 1820	J9980A, J9981A, J9983A, J9984A	All		No support	For use in SFP and SFP+ capable ports. 100Mbps and 1000Mbps is supported on SFP

					ports.
HPE Networking Instant On 1830	JL812A, JL813A, JL814A, JL815A	V2.5.0	V2.5.0	V3.0.0	For use in SFP and SFP+ capable ports. 100Mbps is not supported.
HPE OfficeConnect 1920S	JL381A, JL382A, JL384A, JL385A, JL386A	All		No support	For use in SFP and SFP+ capable ports. 1000Mbps is supported on all SFP ports. 100Mbps is supported with PD.02.16 and later firmware.
HPE Networking Instant On 1930 (A)	JL680A, JL681A, JL682A, JL683A, JL684A, JL685A, JL686A	V1.0.1	V2.5.0	V3.0.0	For use in SFP and SFP+ capable ports. 100Mbps is not supported.
HPE Networking Instant On 1930 (B)	JL683B, JL684B, JL686B	V2.5.0	V2.5.0	V3.0.0	For use in SFP and SFP+ capable ports. 100Mbps is not supported.
HPE OfficeConnect 1950	JH295A, JG960A, JG961A, JG962A, JG963A	1950_7.10. R3507 and 1950_12XGT_7.10. R5106P06		No support	For use in SFP and SFP+ capable ports. 100Mbps is not supported on SFP+ ports.
HPE Networking Instant On 1960	JL805A, JL806A, JL807A, JL808A, JL809A	V2.4.0	V2.5.0	V3.0.0	For use in SFP and SFP+ capable ports. 100Mbps is not supported.
HPE Networking Instant On 1960	S0F35A	V2.8.1	V2.8.1	V3.0.0	For use in SFP and SFP+ capable ports. 100Mbps is not supported.

Access HPE Networking Instant On support and updates, and view warranty and regulatory information.

Accessing HPE Networking Instant On Support

HPE Networking Instant On Support Services	https://instant-on.hpe.com/contact-support/
HPE Networking Instant Support On community	https://community.instant-on.hpe.com/support
HPE Networking Instant On community	https://community.instant-on.hpe.com/home
Contact telephone number	https://instant-on.hpe.com/contact-support/#contact

Be sure to collect the following information before contacting Support:

- Technical support registration number (if applicable)
- Product name, model or version, and serial number
- Operating system name and version
- Firmware version
- Error messages
- Product-specific reports and logs
- Add-on products or components
- Third-party products or components

Other useful sites

End-of-Life information can be found at <https://networkingsupport.hpe.com/>.

Accessing updates

You can access updates from the HPE Networking Instant On Support Services Website.

OfficeConnect Support Portal

If you are unable to find your product in the HPE Networking Instant On Support Portal, you may need to search the [OfficeConnect portfolio support portal](#). HPE Networking Instant On portfolio has replaced HPE OfficeConnect portfolio.

Warranty information

To view warranty information for your product, go to <https://www.hpe.com/us/en/networking/hpe-aruba-networking-support-services.html>.

Regulatory information

To view the regulatory information for your product, view the *Safety and Compliance Information for Server, Storage, Power, Networking, and Rack Products*, available at <https://www.hpe.com/support/Safety-Compliance-EnterpriseProducts>

Additional regulatory information

HPE Aruba Networking is committed to providing our customers with information about the chemical substances in our products as needed to comply with legal requirements, environmental data (company programs, product recycling, energy efficiency), and safety information and compliance data, (RoHS and WEEE). For more information, see <https://www.hpe.com/us/en/living-progress.html>.

Documentation feedback

HPE Aruba Networking is committed to providing documentation that meets your needs. To help us improve the documentation, send any errors, suggestions, or comments to Documentation Feedback (docsfeedback-switching@hpe.com). When submitting your feedback, include the document title, part number, edition, and publication date located on the front cover of the document. For online help content, include the product name, product version, help edition, and publication date located on the legal notices page.